

Hiipakka

- Since 1951 -

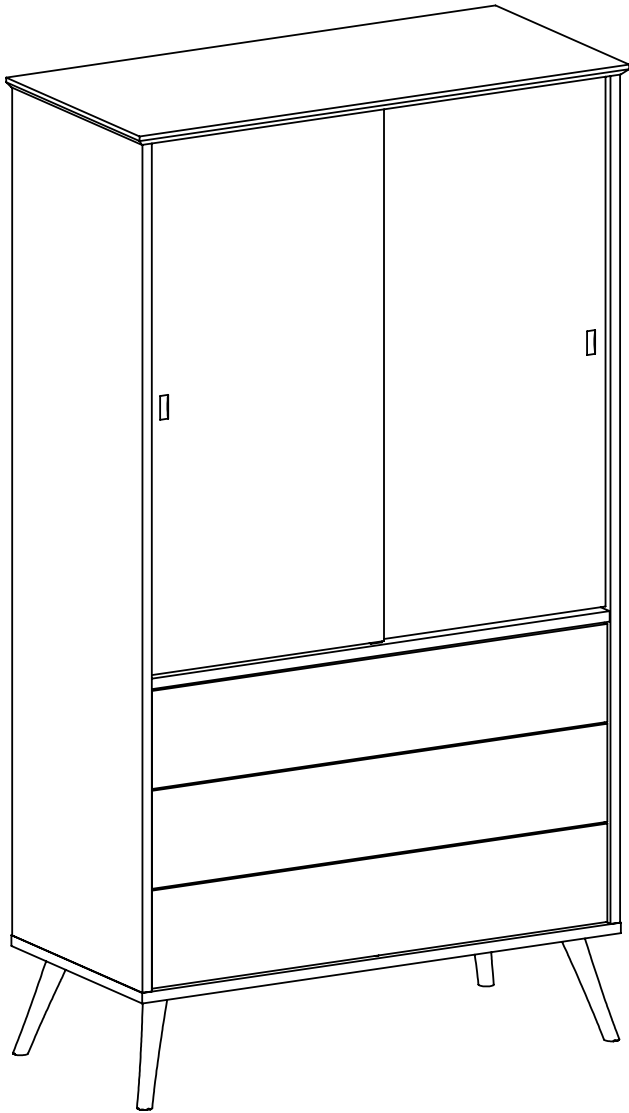

Emma

Vitriini
Viola / cabinet

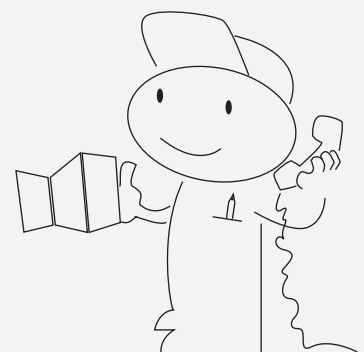
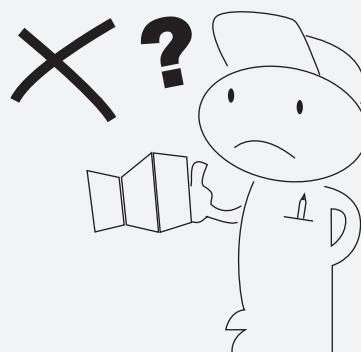
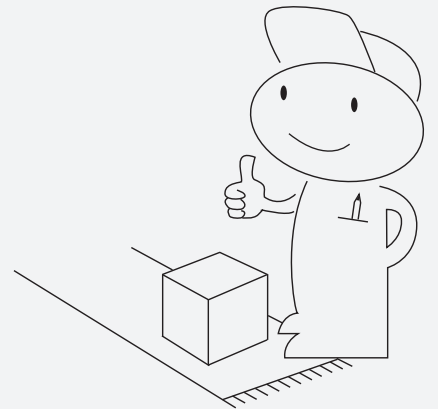
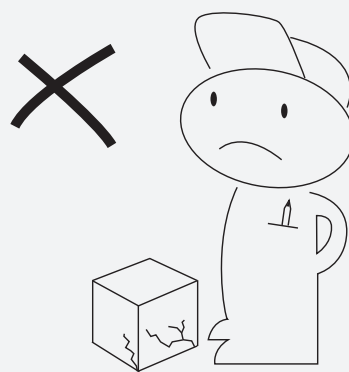



www.hiipakka.net
Phone: +358 20 7689 500

E J Hiipakka Oy
Teollisuustie 1
FI - 66300 JURVA, FINLAND

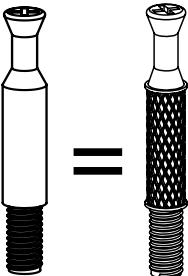

Pusseissa / i påsar / in bags

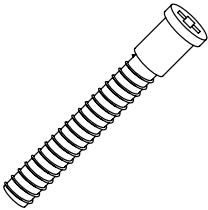
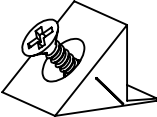
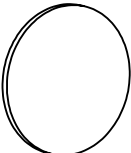
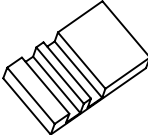
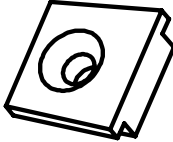
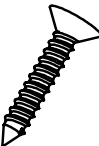
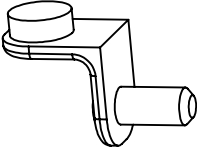
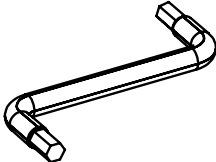
28x	8 x	8 x	4 x
			
6 x	4 x	1 x	1 x
			
1 x	8 x		
			

x 4



1

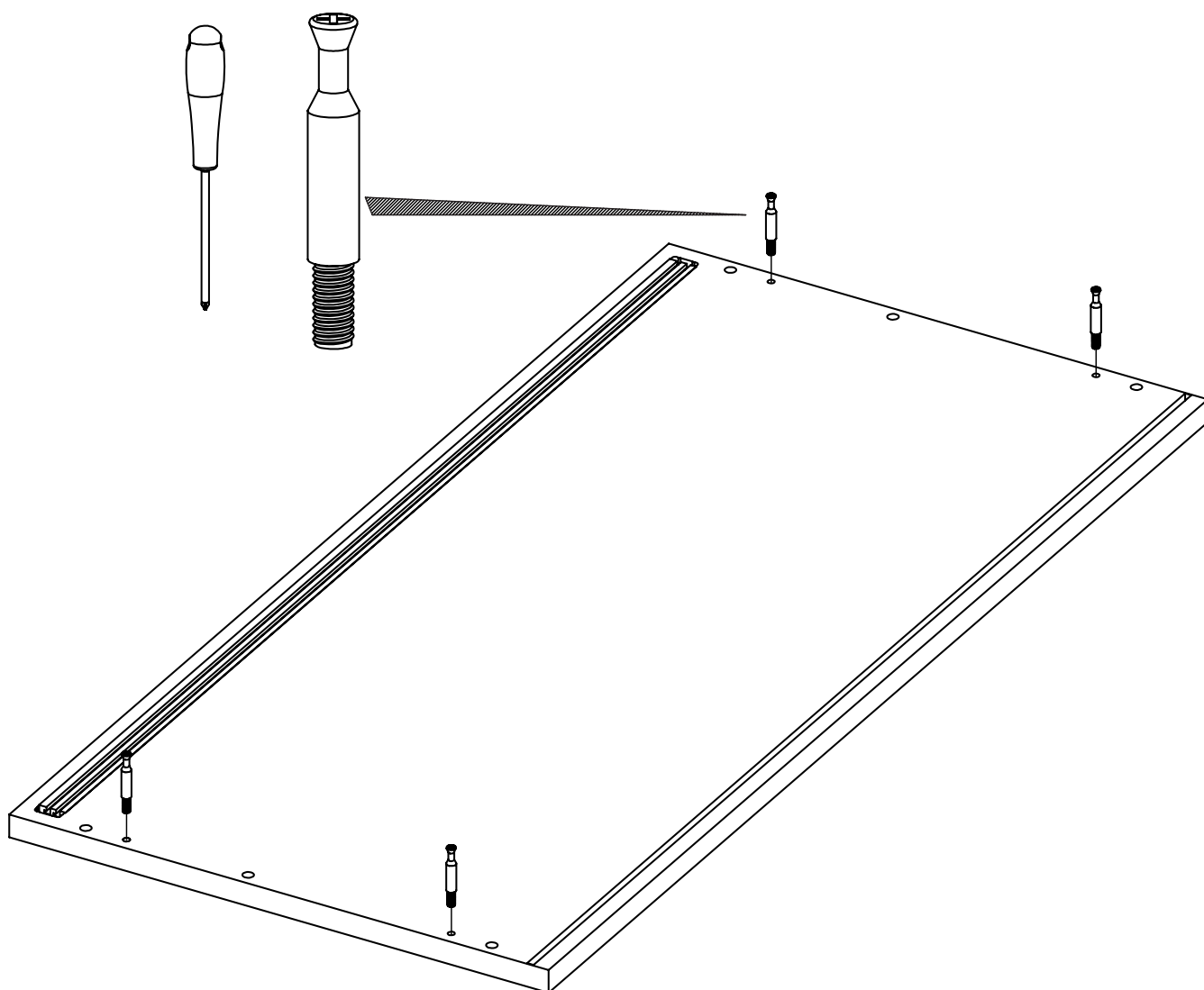

x 12

x 4

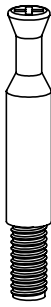
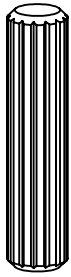

2

Vasen
Vänster
Left

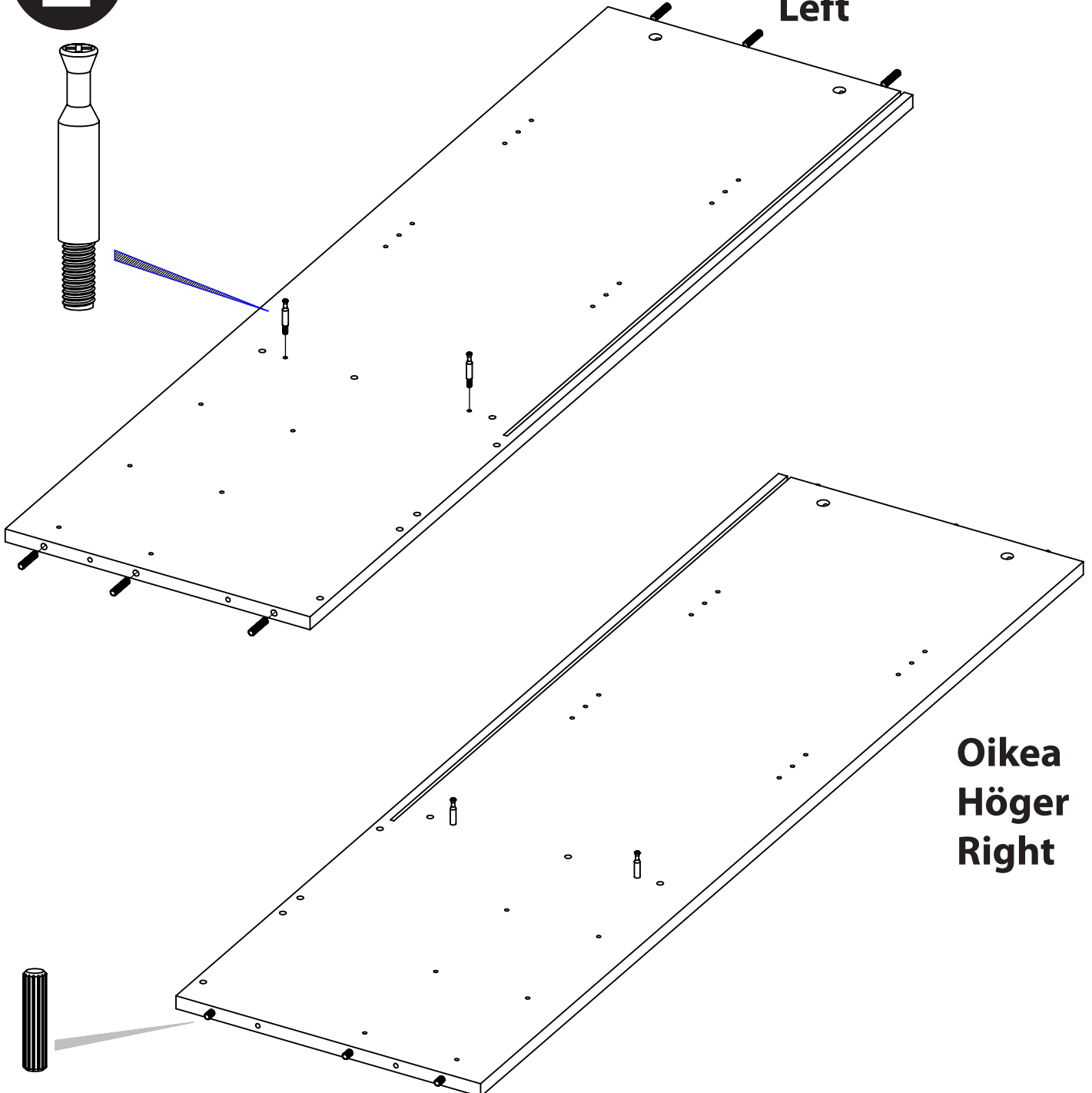

Oikea
Höger
Right

x 6

x 4

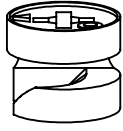
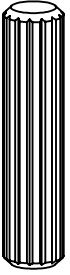

3

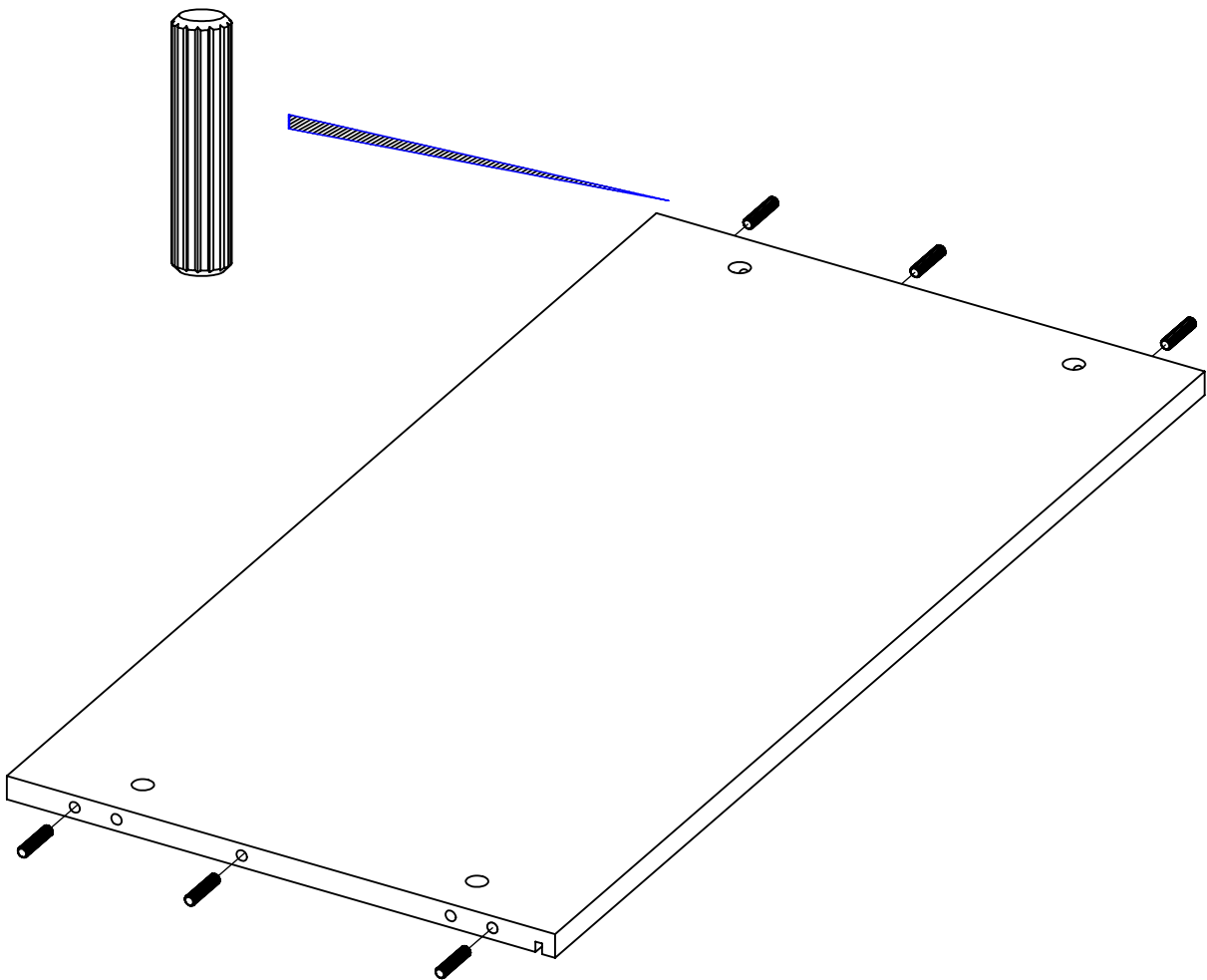

x10



4

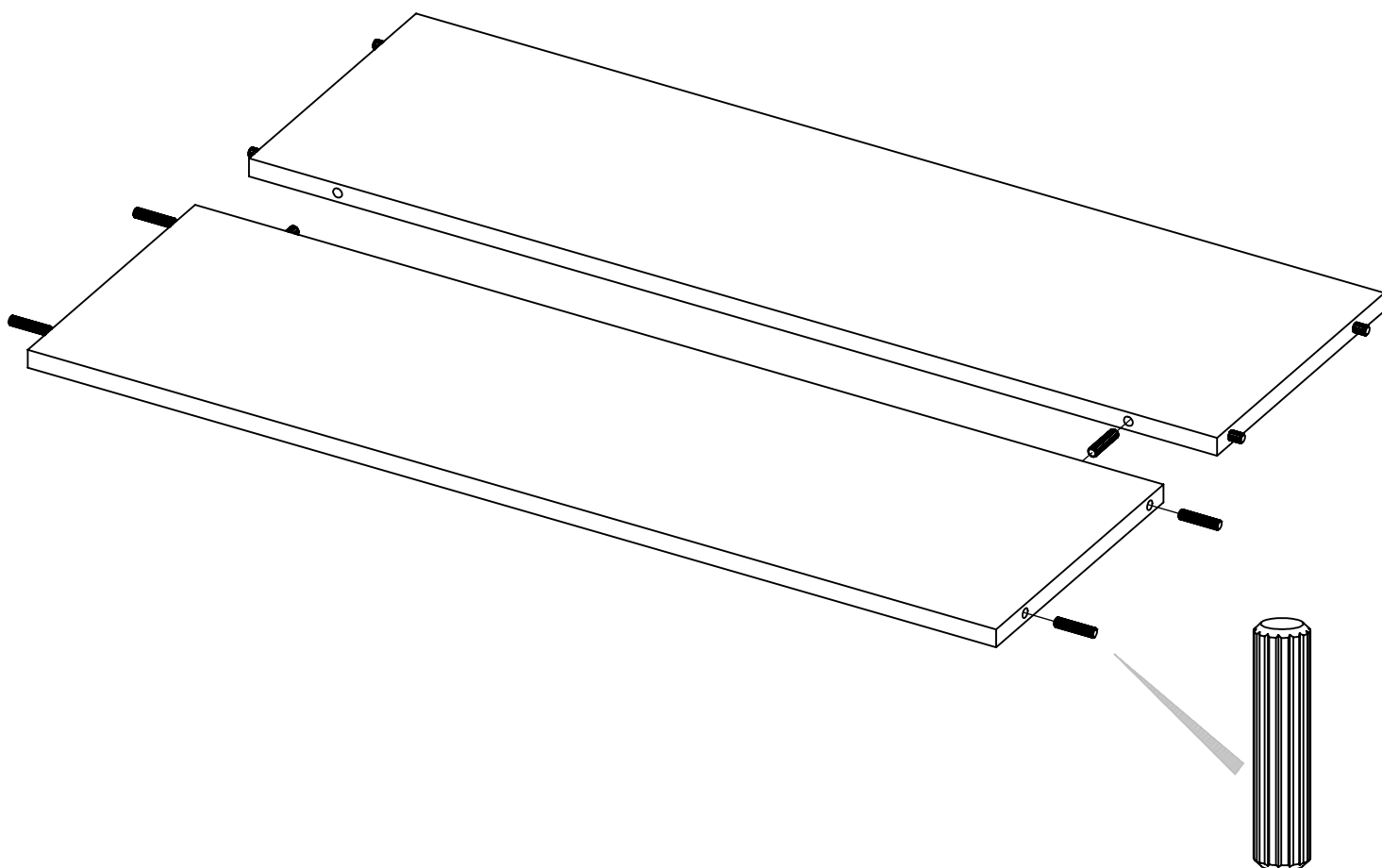

x 4

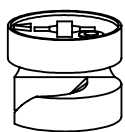

5

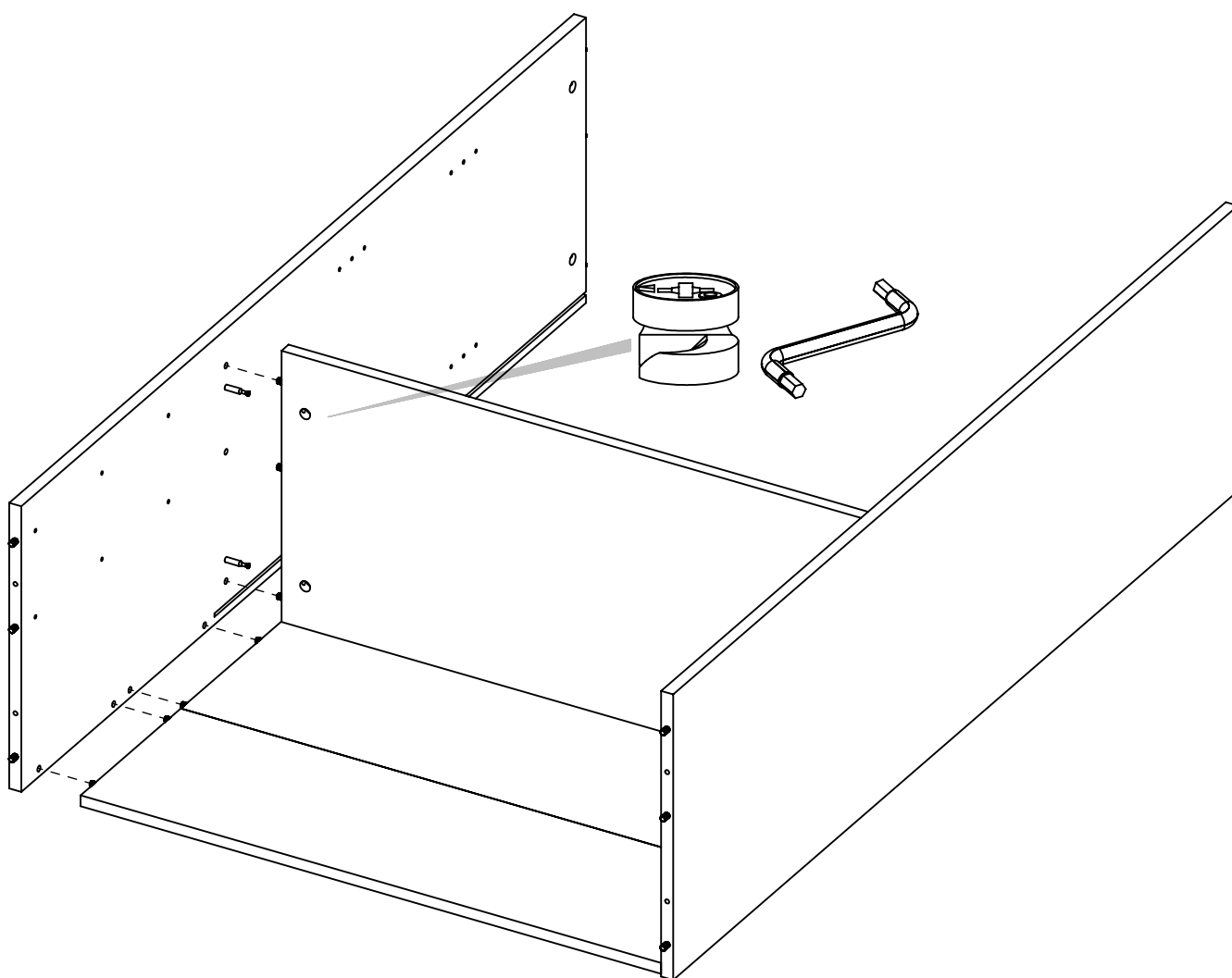

x 4



6

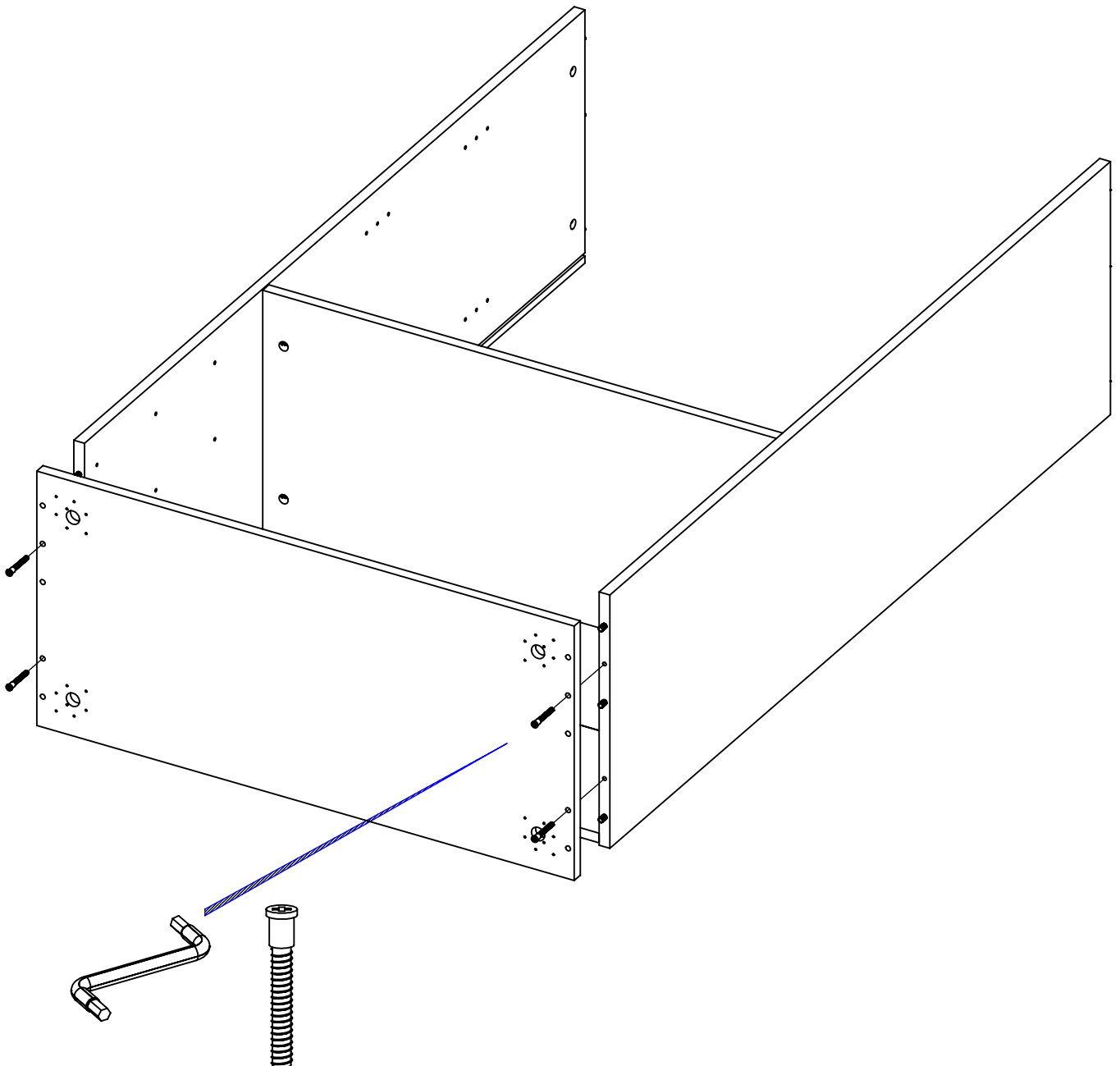

7

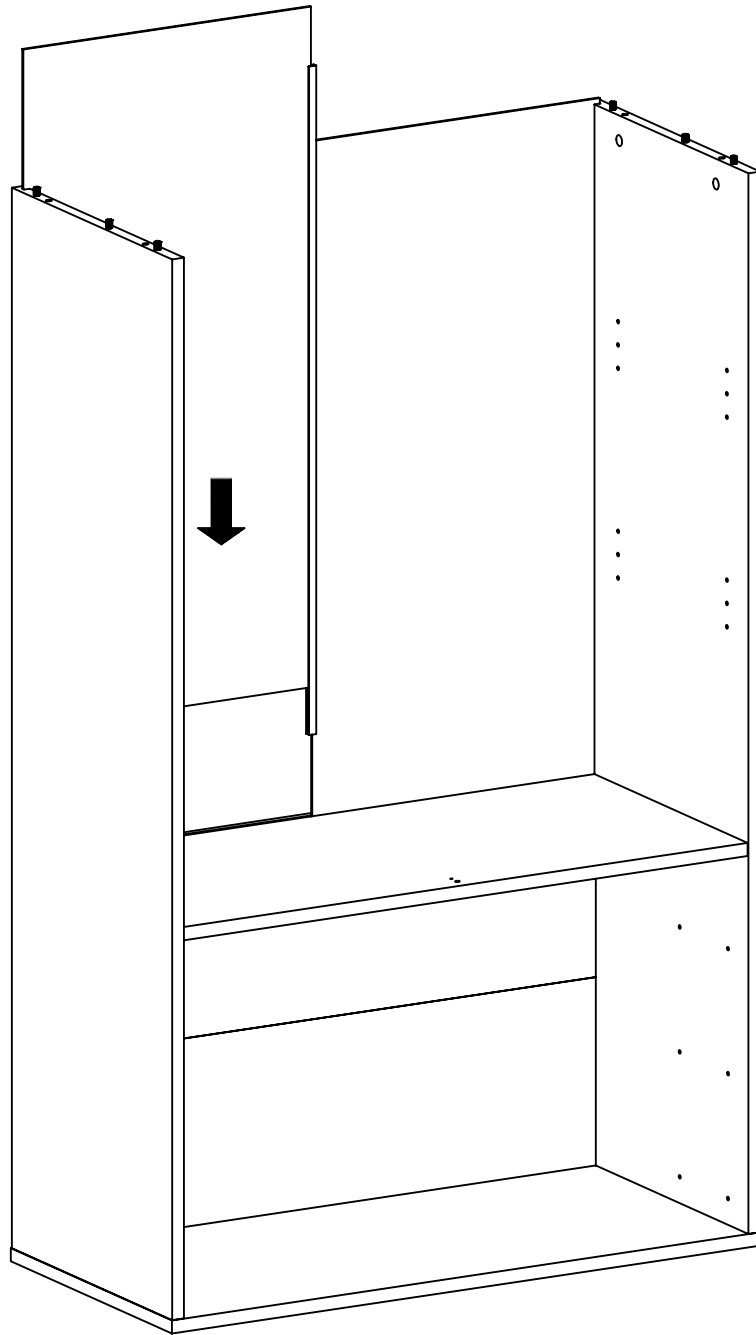

x 4

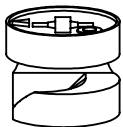

8

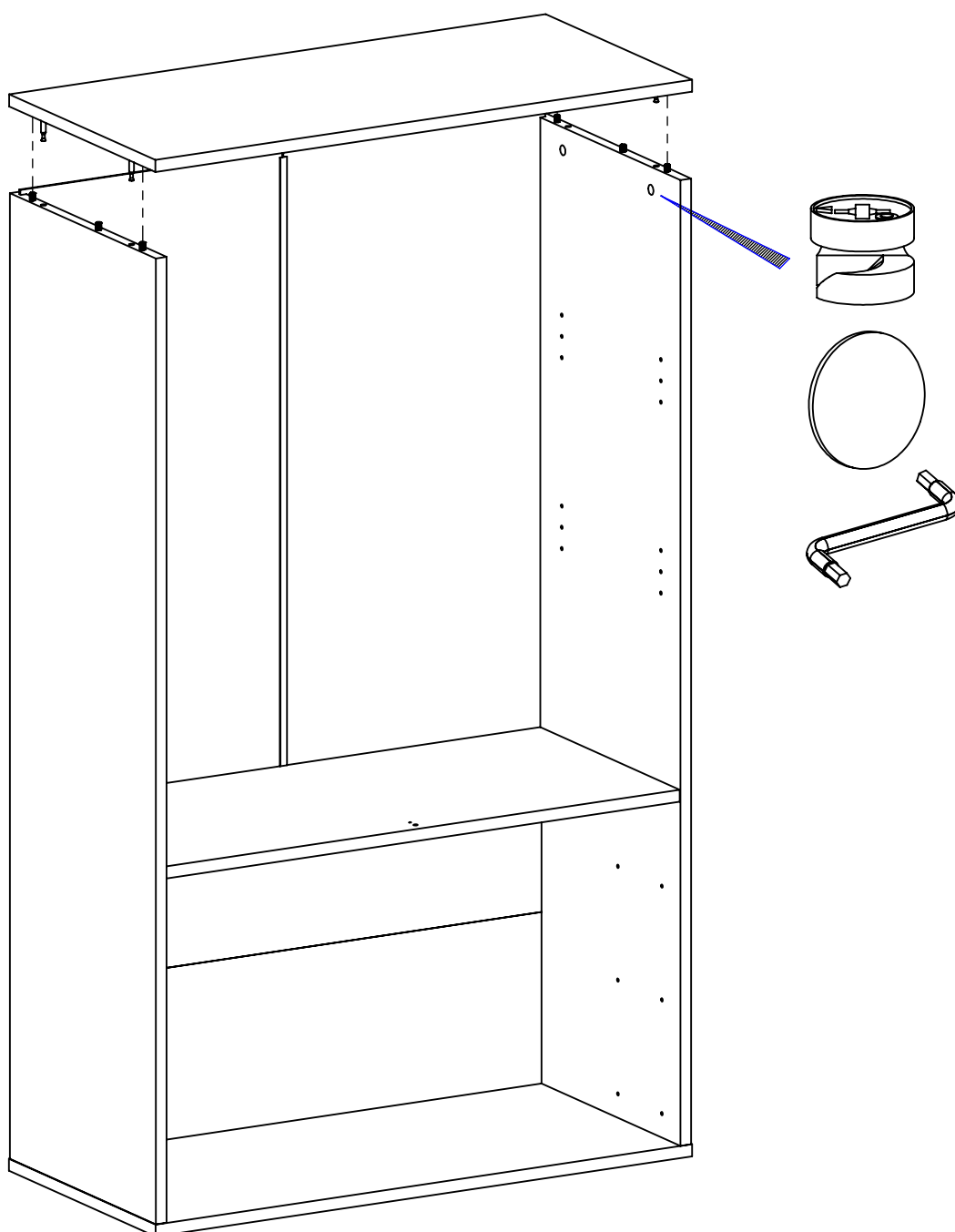

x 6

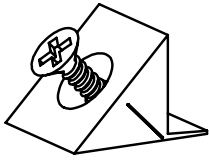

2

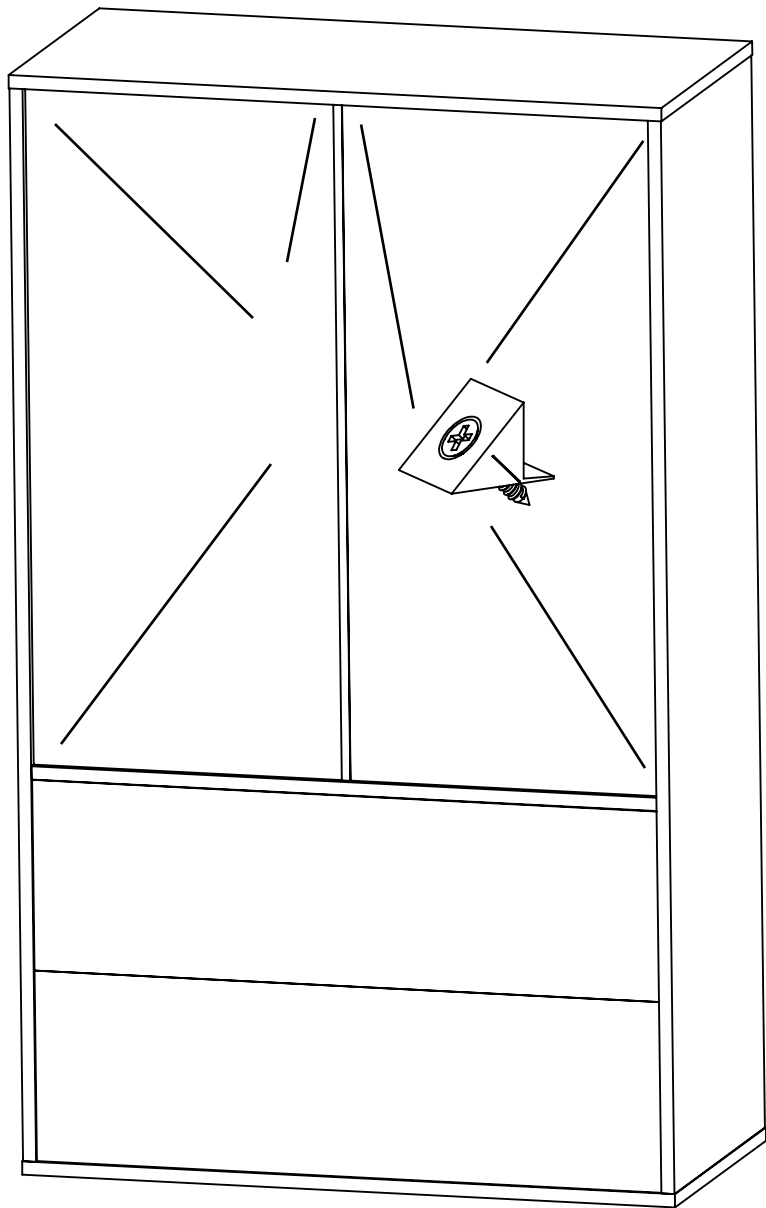
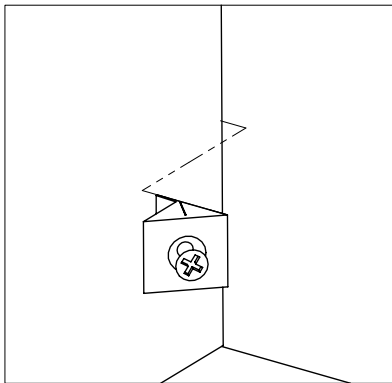
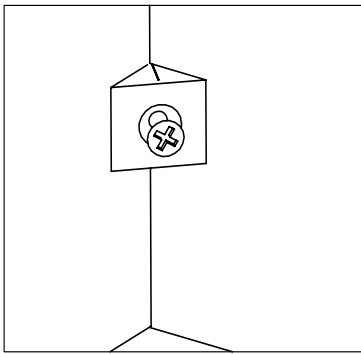

Tarkista ristimita
Kontrollera kryssmättet
Check the crosswise measure

x1

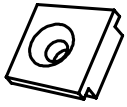

x1

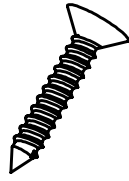

x8

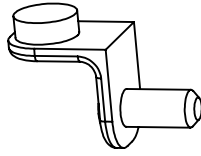

10

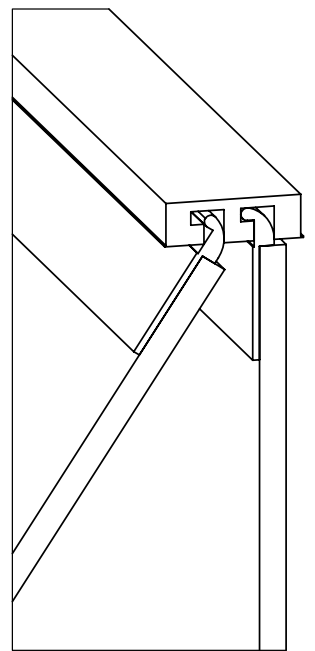
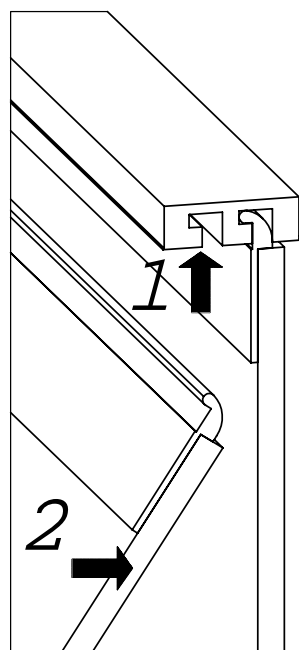
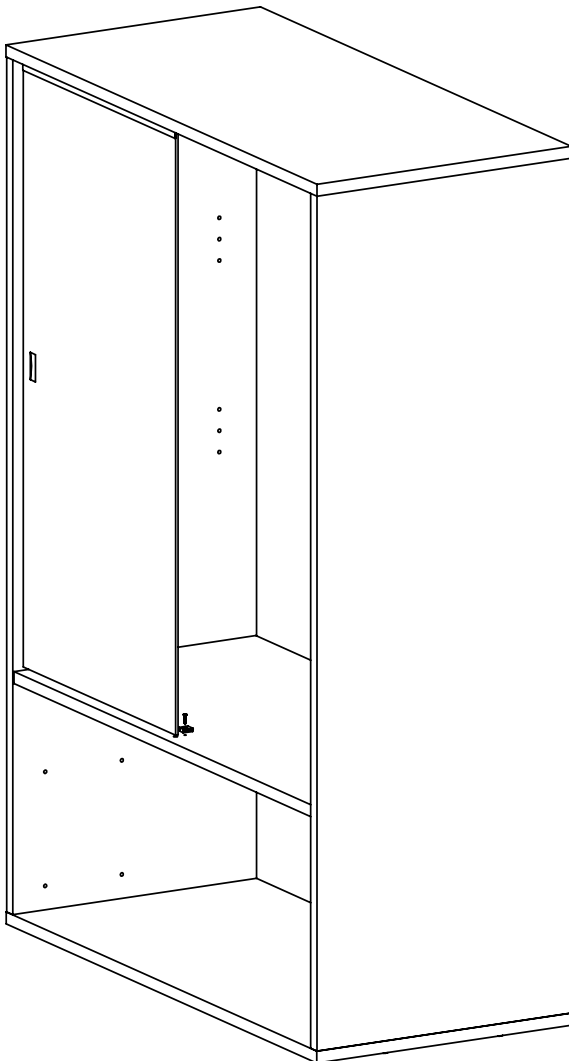
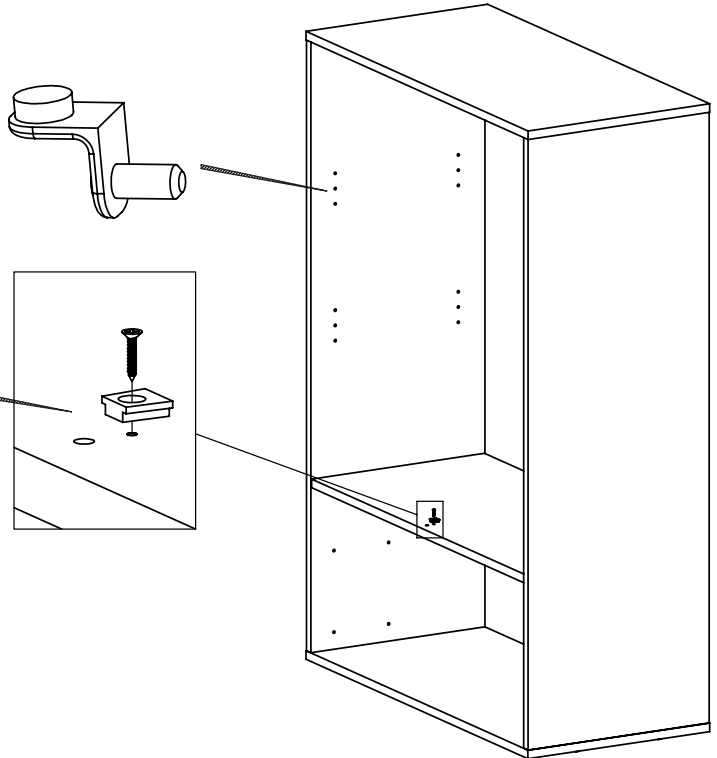
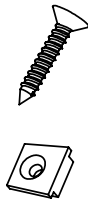
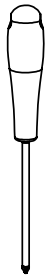

x 1

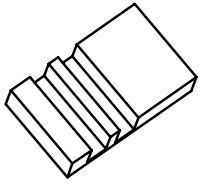

11

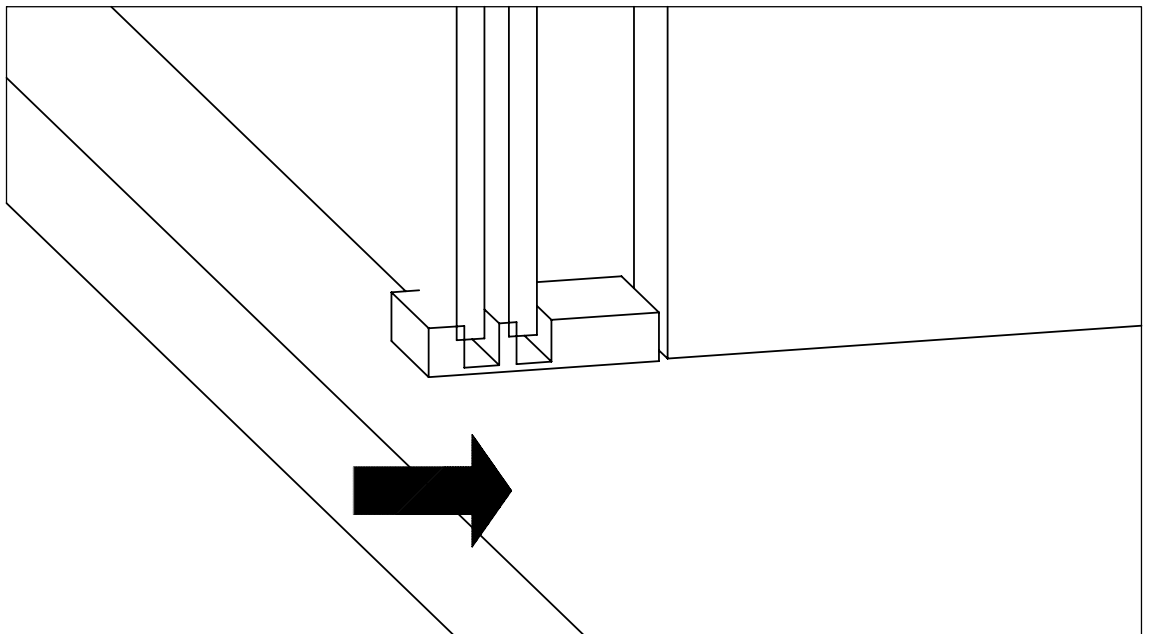
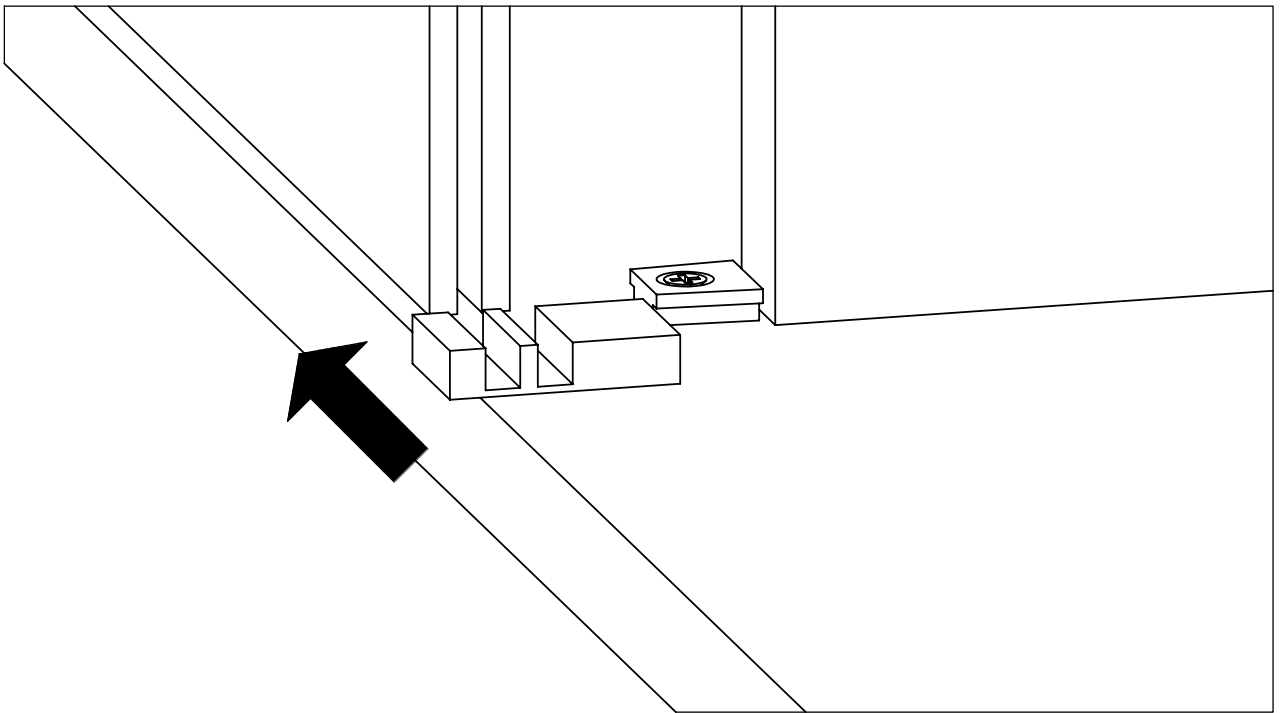



Pusseissa / i påsar / in bags

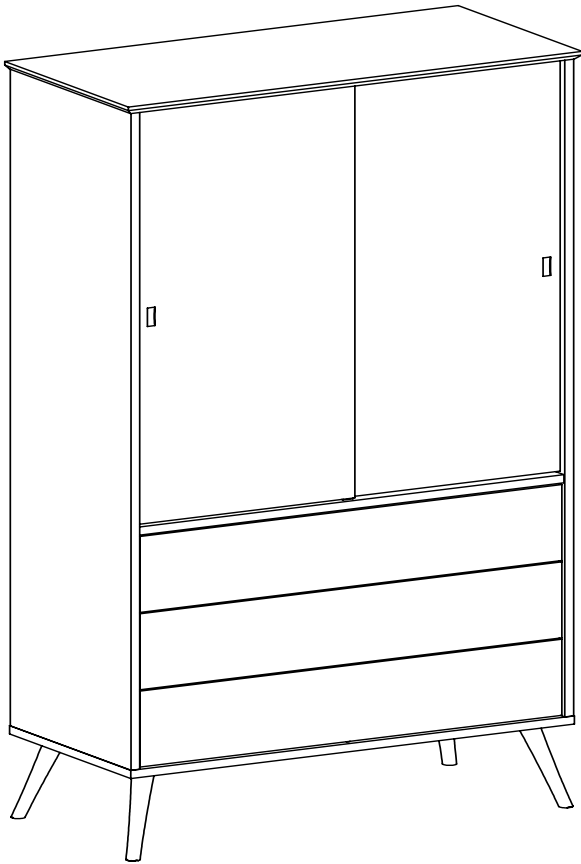

Emma

Laatikko
Viola / Drawer

12x	12x	6x	12x

x12



12

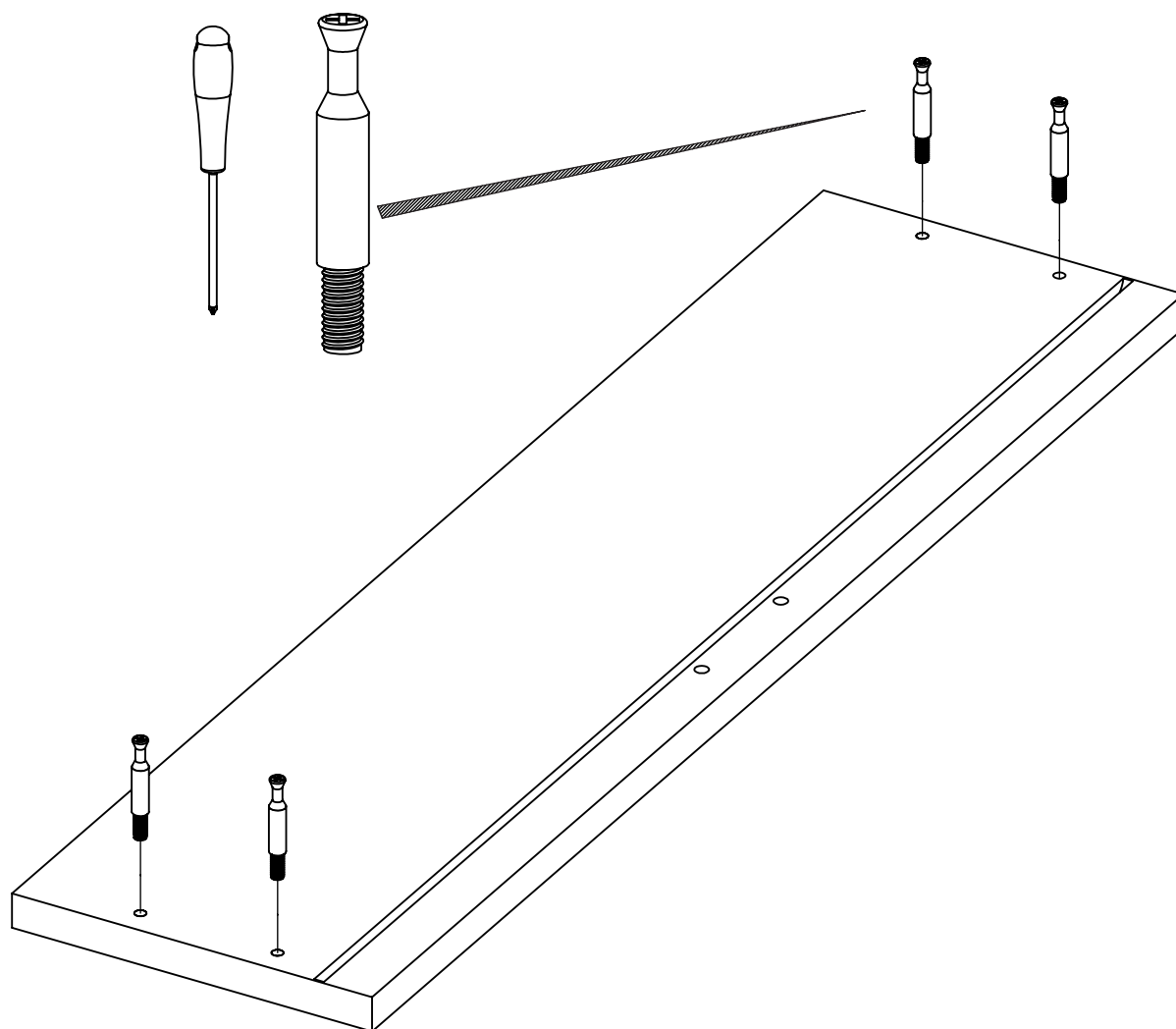

x 6



13

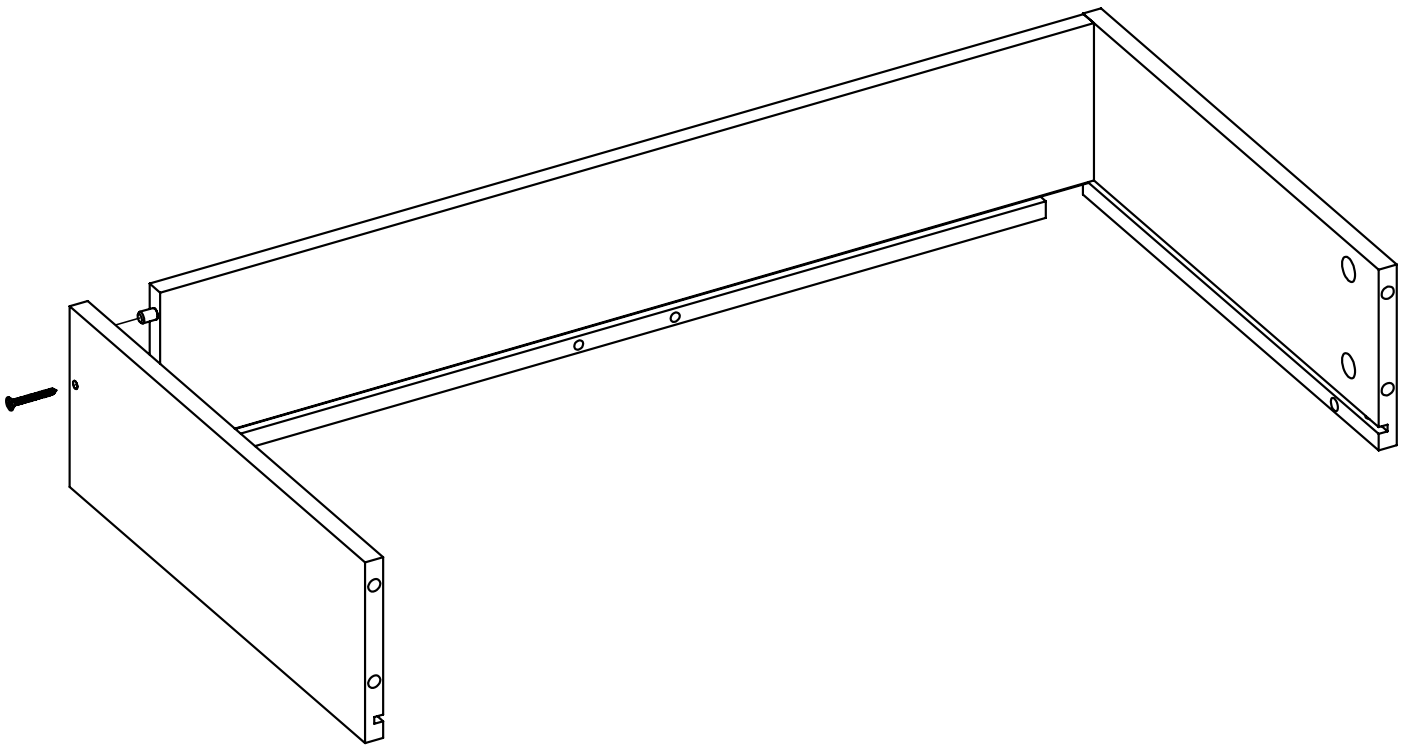

x12

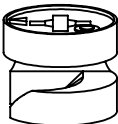

14

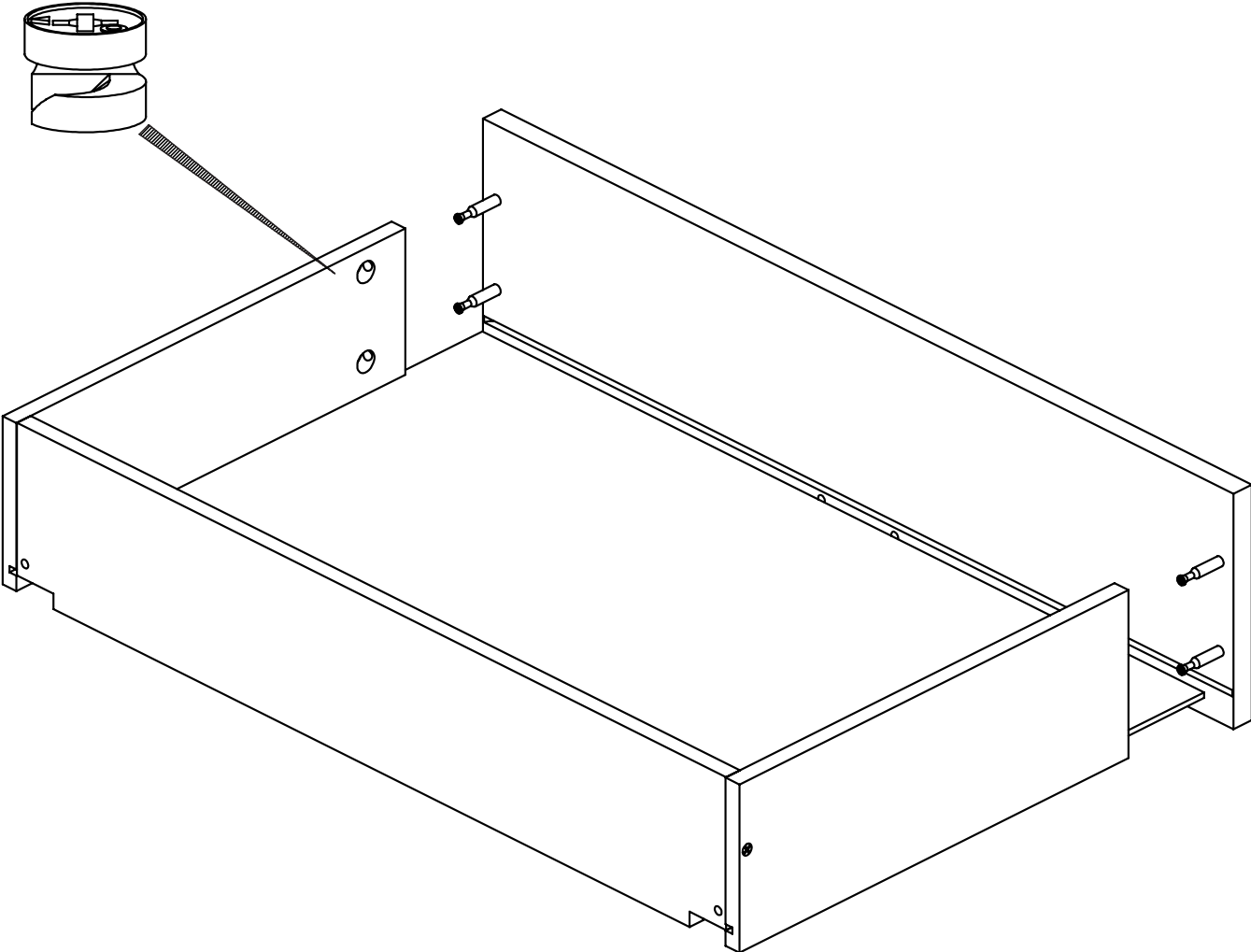

x12



15

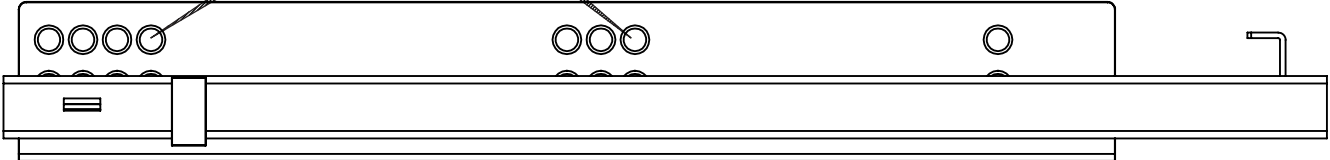
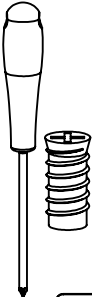
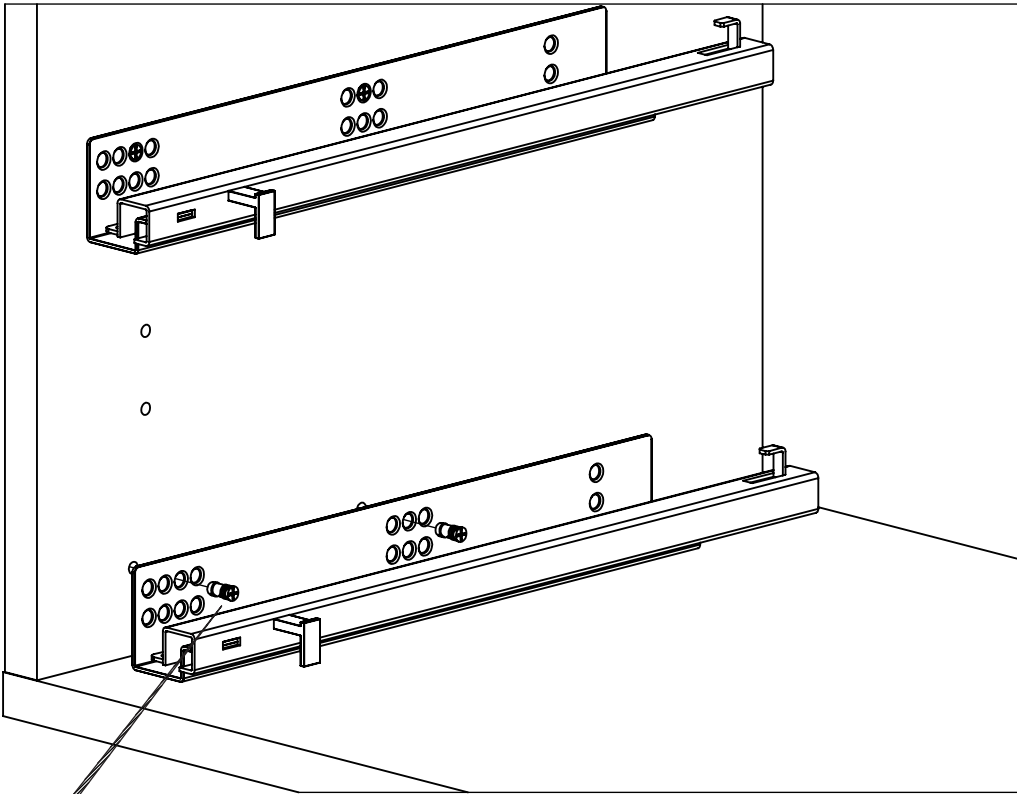

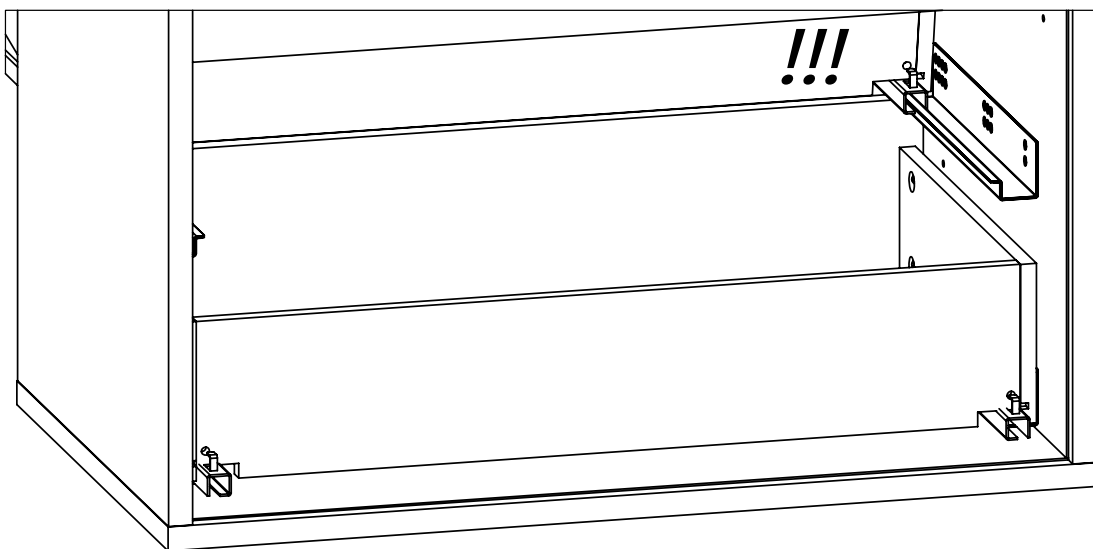
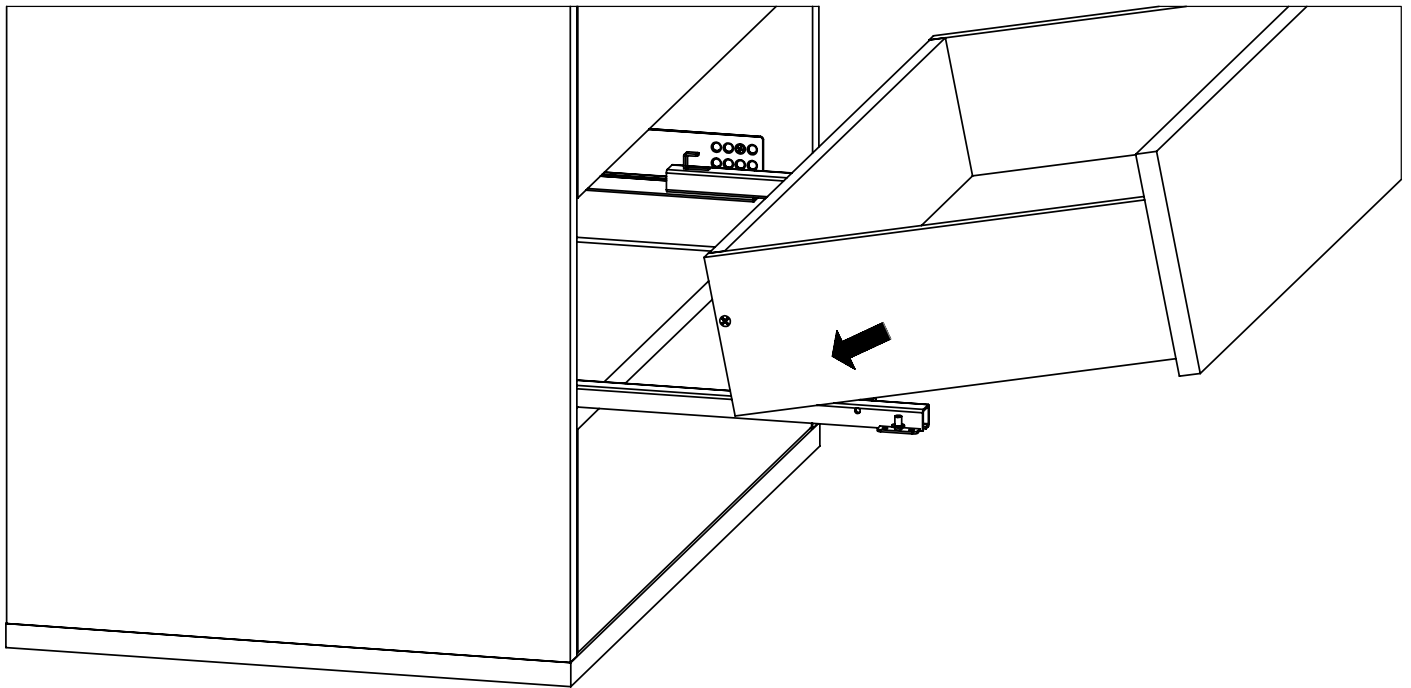

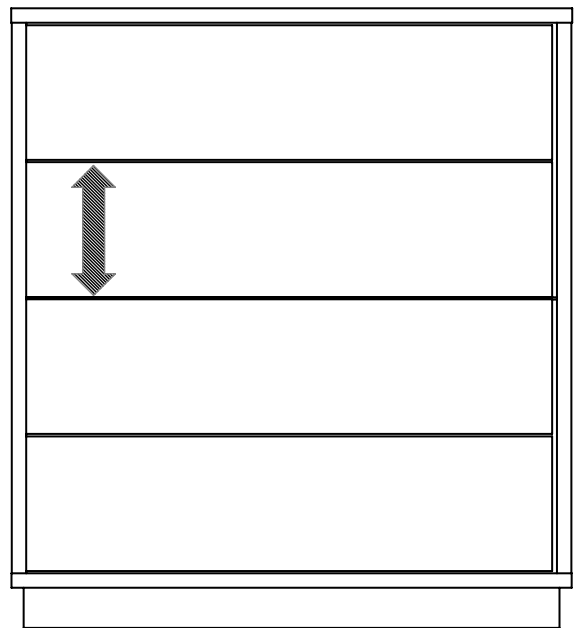
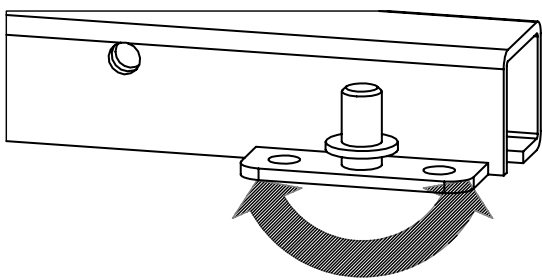
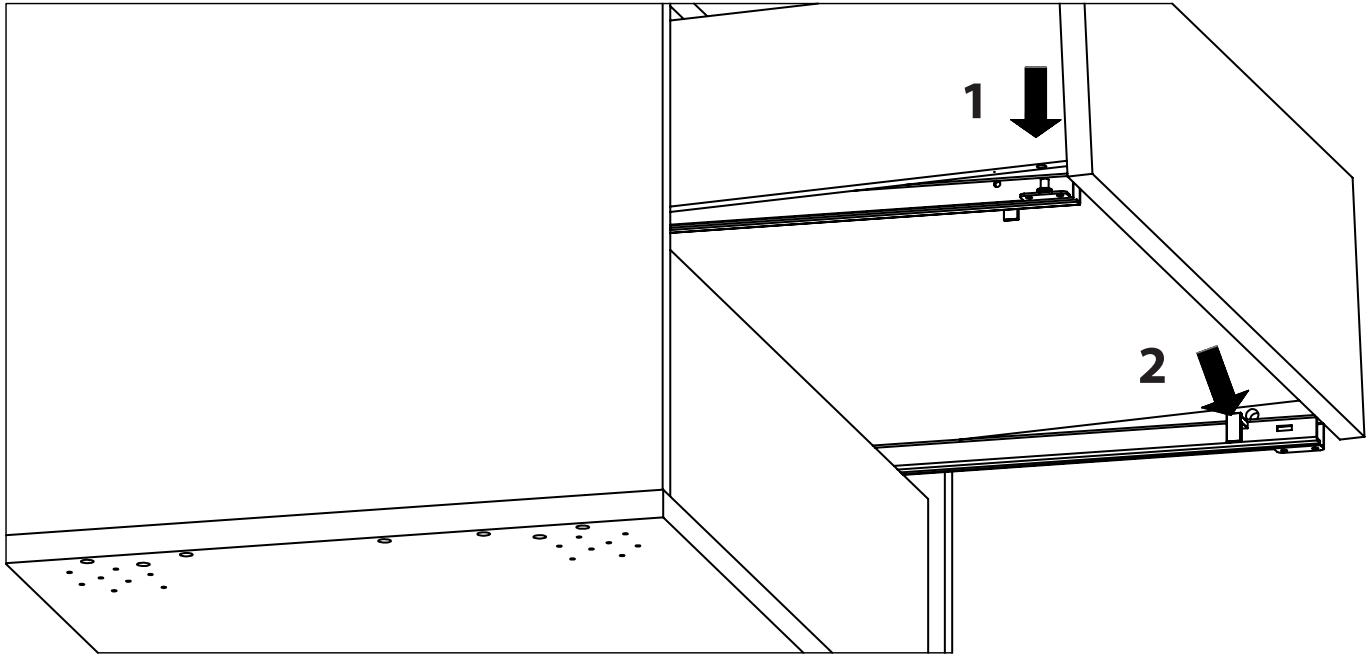

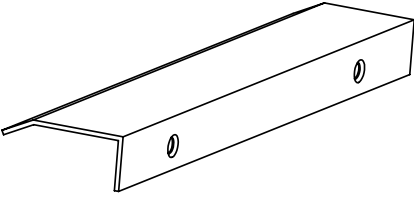
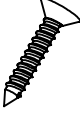
3x	6x
	

18

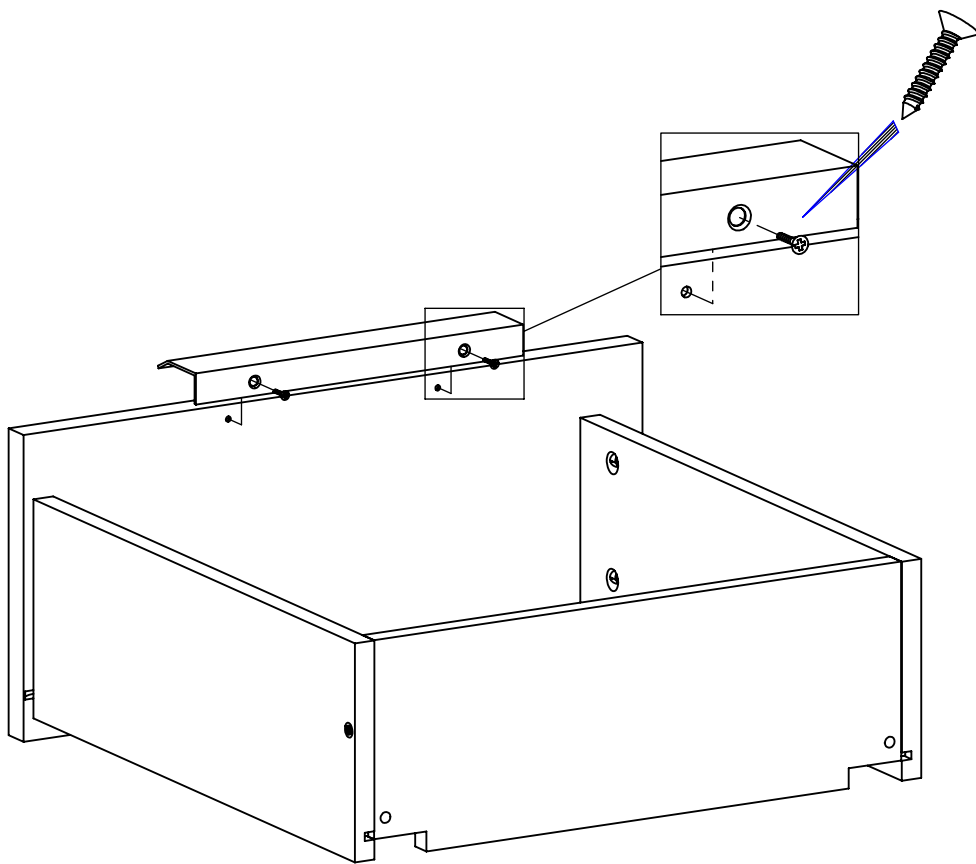

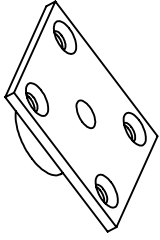
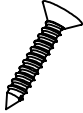
4x	16x
	

19

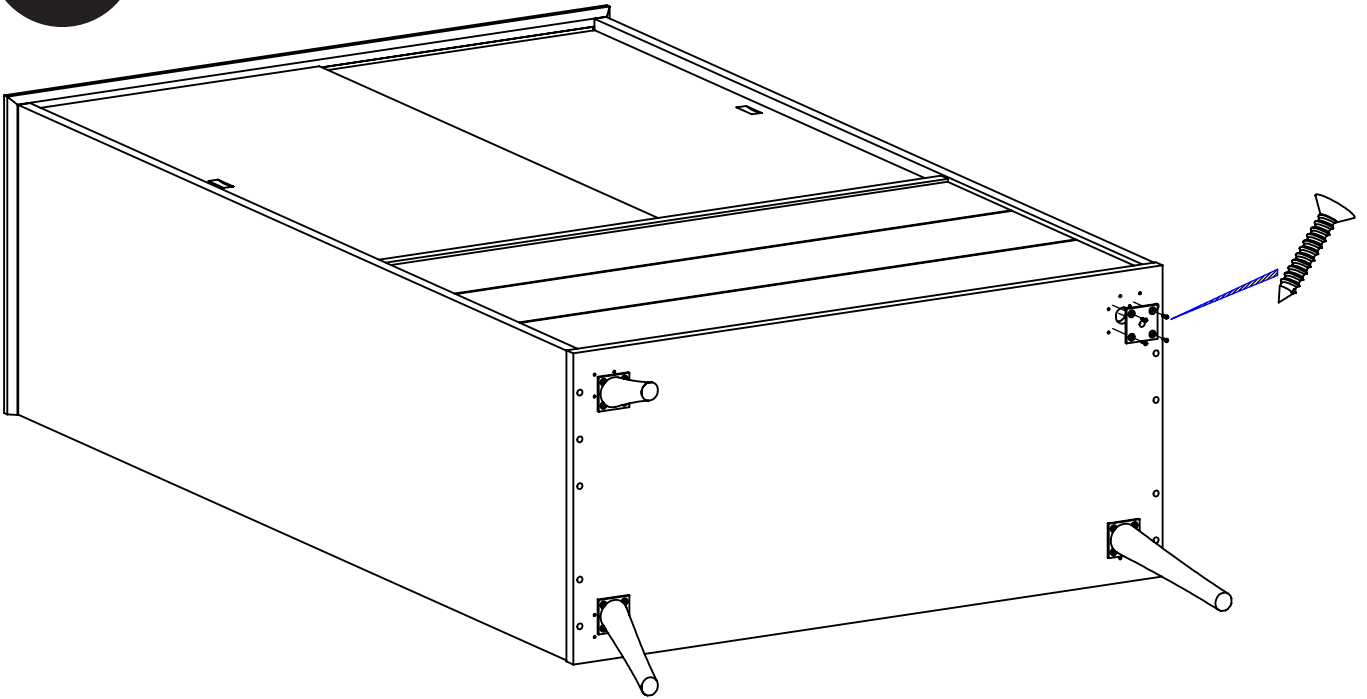

!!!

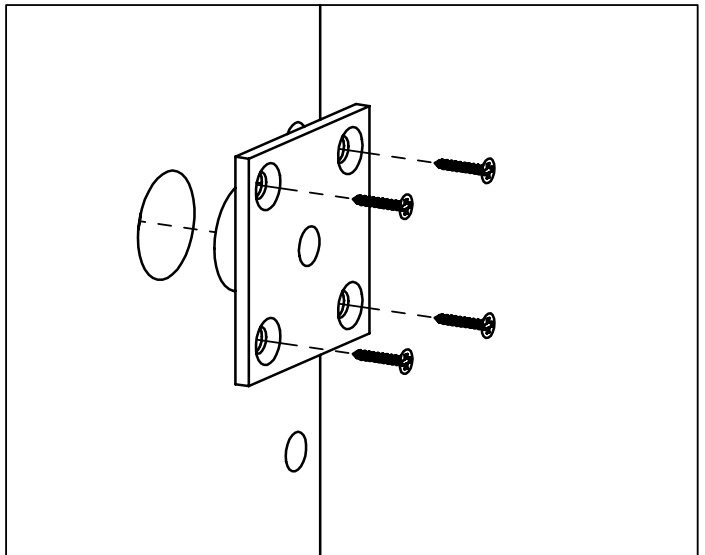

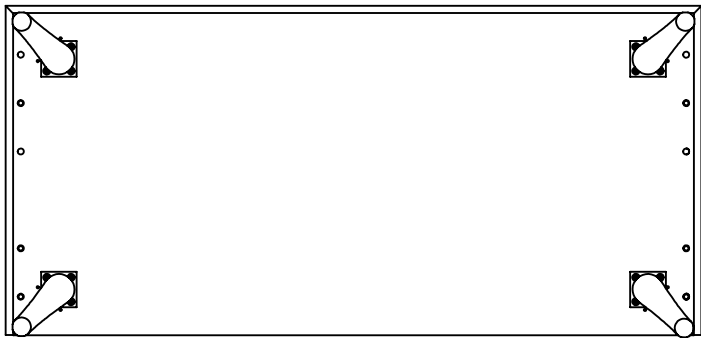
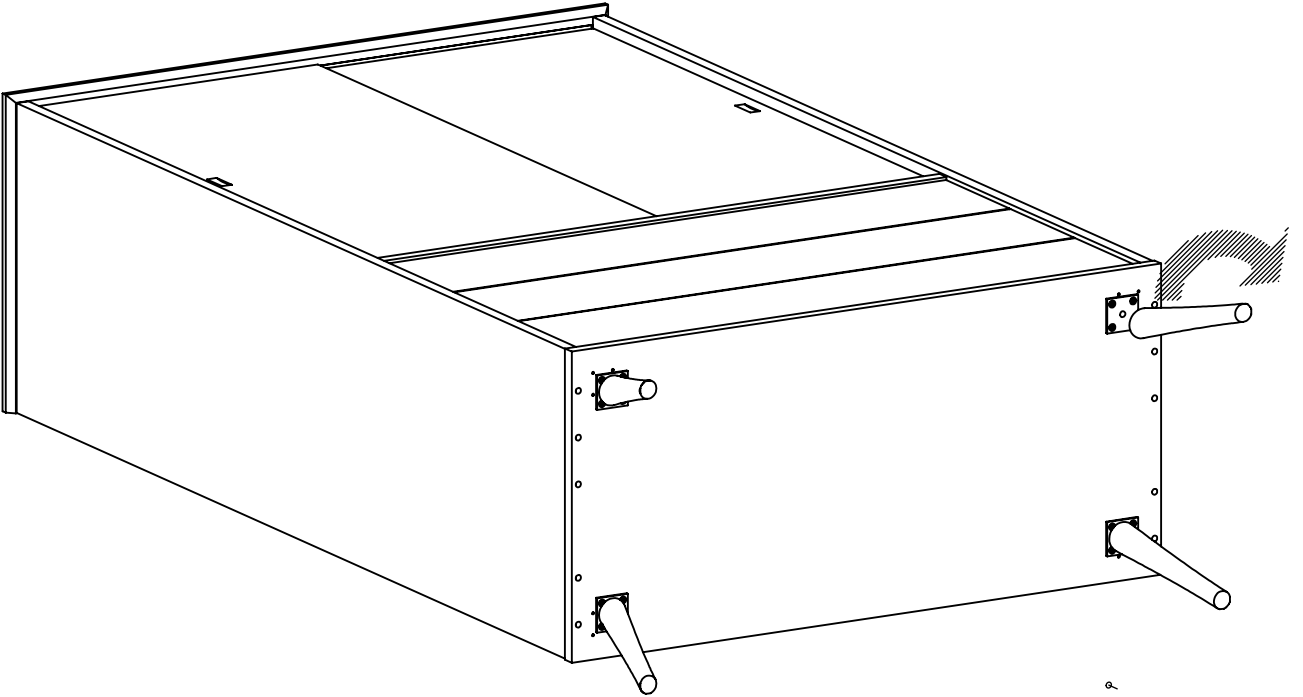

Hiipakka

- Since 1951 -

valaisin lisävarusteena

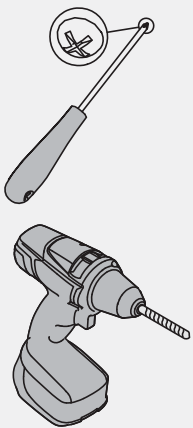
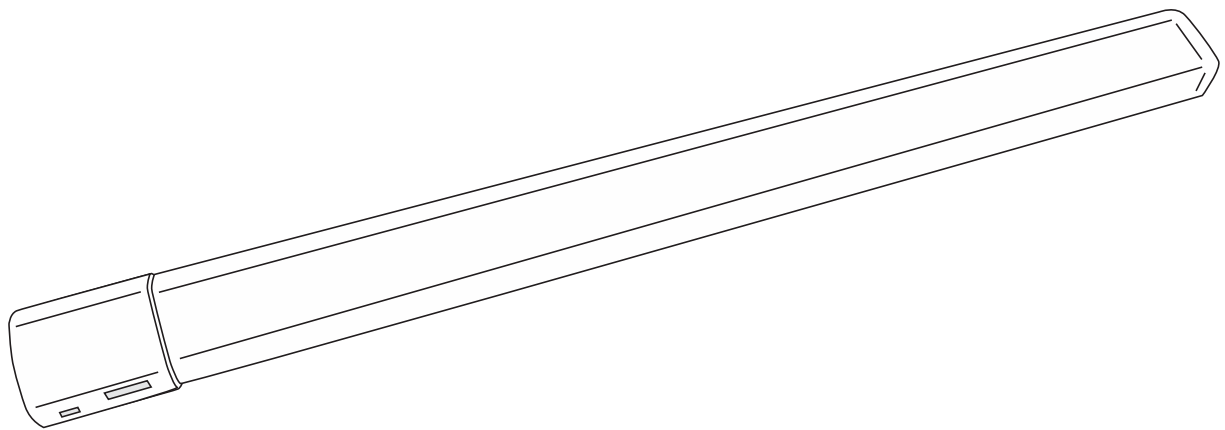

1 x

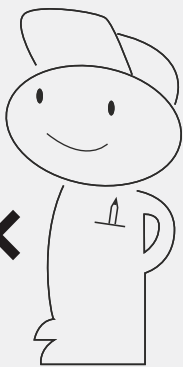

X ?

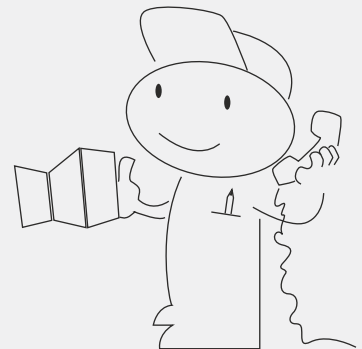

www.hiipakka.net
Puh. 020 768 9500

E J Hiipakka Oy
Teollisuustie 1
FI - 66300 JURVA, FINLAND

-VALAISIN, PAKKAUKSEN SISÄLTÖ:

- 1 kpl Paiste-valaisimia 12 V / 3 W
- virtalähde (muuntaja) 12 V / 6W

- kiinnikkeet
- ruuvit

Tarkista ennen asennusta, että kaikki osat ovat mukana.

Huom! Valaisimen asennuksessa on otettava huomioon voimassa olevat sähköturvallisuusmääräykset. Valaisin on tarkoitettu käytettäväksi vain asunnoissa ja muissa vastaavissa kuivissa sisätiloissa.

1

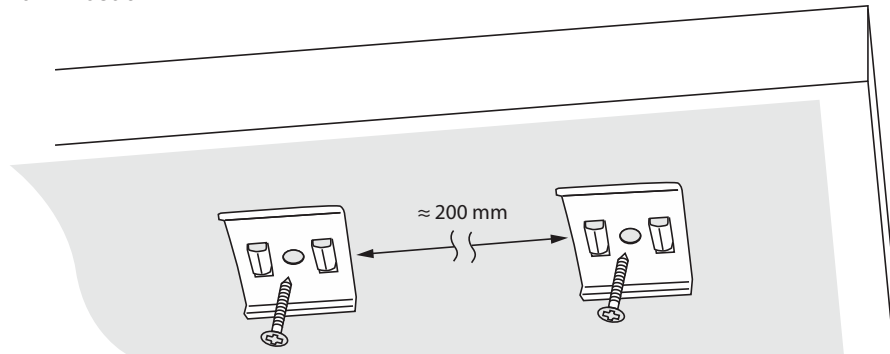

Kiinnitä valaisimen asennuslevyt.
Työhelpottamiseksi suosittelemme ns. esireikien tekoa esim.merkkauspiikillä.



2

Paina valaisin metallikiinnikkeisiin.

3

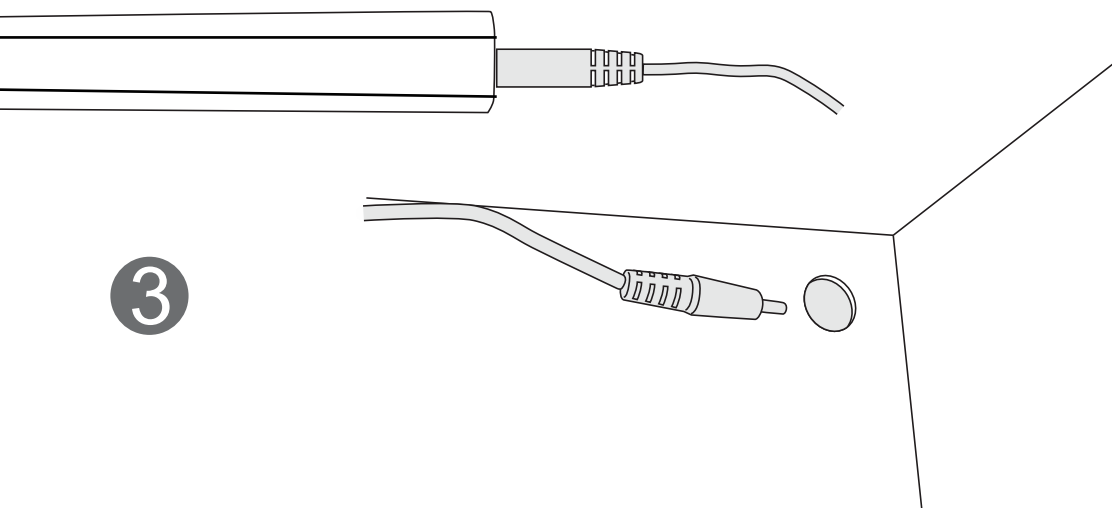

4

Tämän jälkeen voit laittaa virtalähteen pistokkeen pistorasiaan.

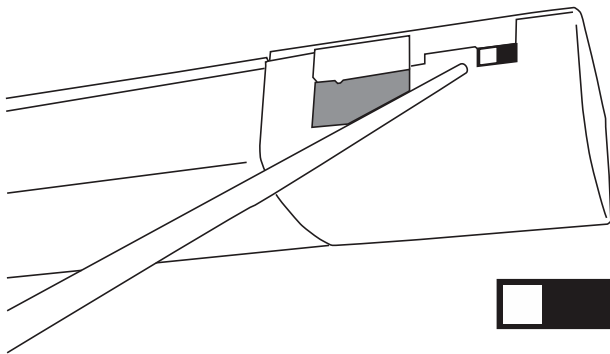
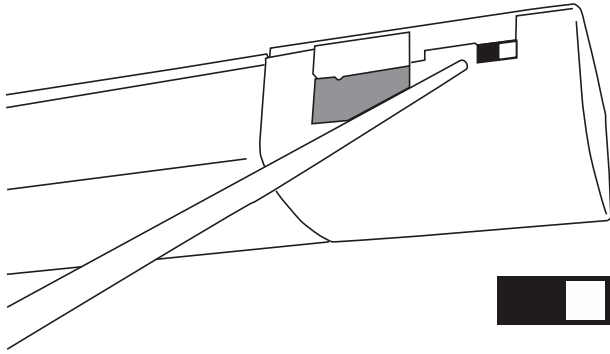

5

Nyt voit käyttää valaisinta kahdella tavalla.

1. Siirrä pieni valkoinen kytkin kuvan osoittamaan reunaan esim. hammastikun avulla. Nyt valaisinta voidaan käyttää käden liikkeellä. Valaisin tunnistaa liikkeen noin 3 cm päästä.

TAI

2. Siirrä kytkin kuvan osoittamaan reunaan, ja valaisin syttyy ja sammuu automaattisesti ovea avattaessa tai suljettaessa.

6

Mikäli käytössä on katkaisimella varustettu pistokemuuntaja. Asenna muuntajasta tuleva johto valaisimen toiseen päähän. Näin voit käyttää muuntajan katkaisinta.

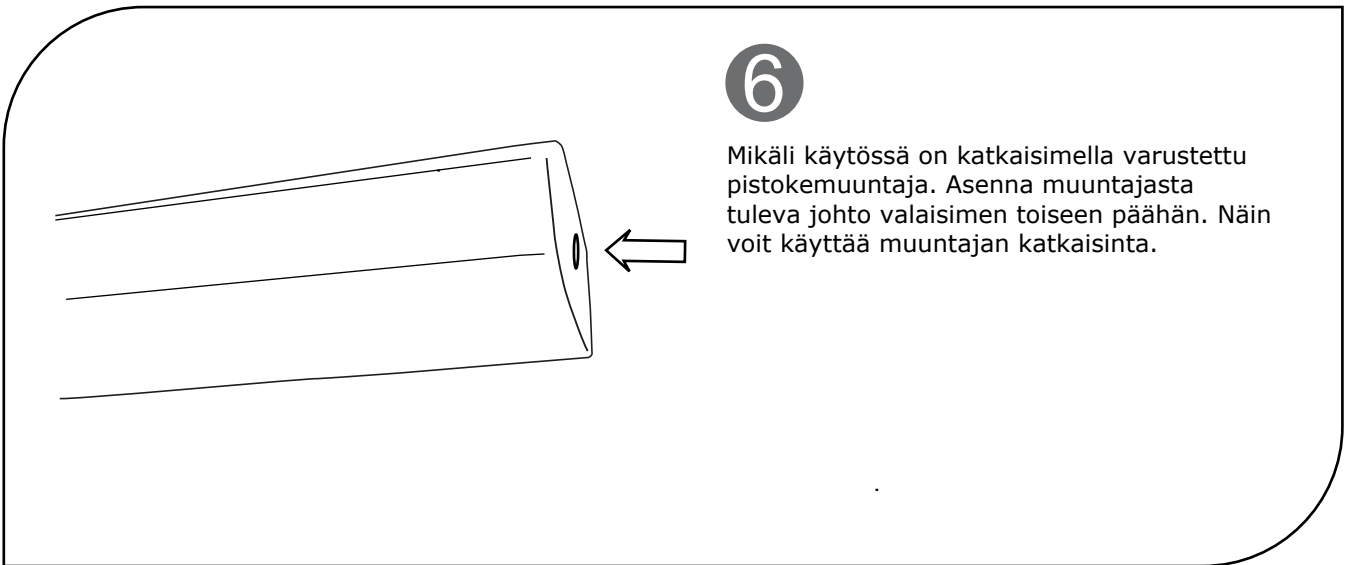

Hiipakka

- Since 1951 -

belysning set extra tillbehör
Lighting set optional

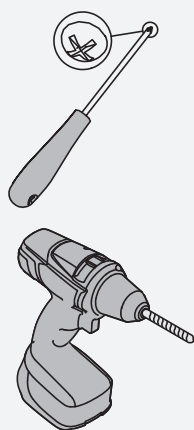
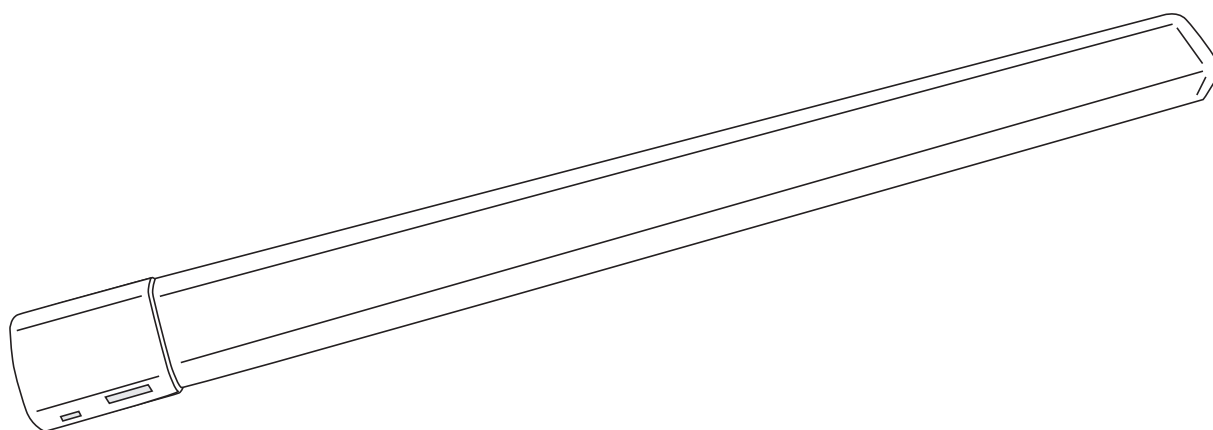

1 x

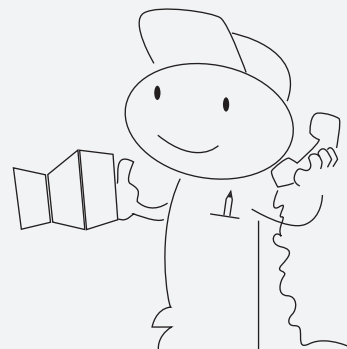
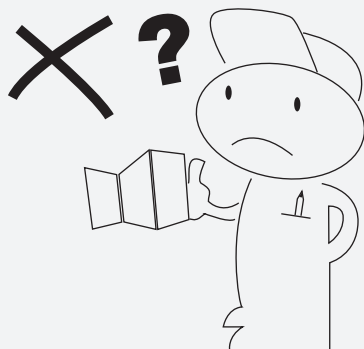
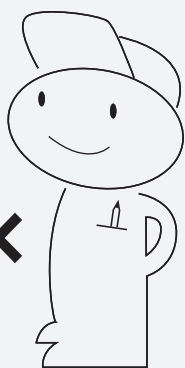

www.hiipakka.net
Tfn +358 20 768 9500

E J Hiipakka Oy
Teollisuustie 1
FI - 66300 JURVA, FINLAND

BELYSNING, FÖRPACKNINGENS INNEHÅLL:

- 2 st Paiste-belysningar 12 V / 3 W
- strömkälla (transformator) 12 V / 15 W
- fördelningsdosa
- 2 st kablar (hane-hane)
- fästelement
- skruvar

Kontrollera att alla delar finns med innan du börjar montera belysningen.

Obs! Gällande elsäkerhetsbestämmelser bör beaktas vid monteringen av belysningen.

Belysningen är avsedd att användas endast i bostäder och andra motsvarande torra inomhusutrymmen.

1

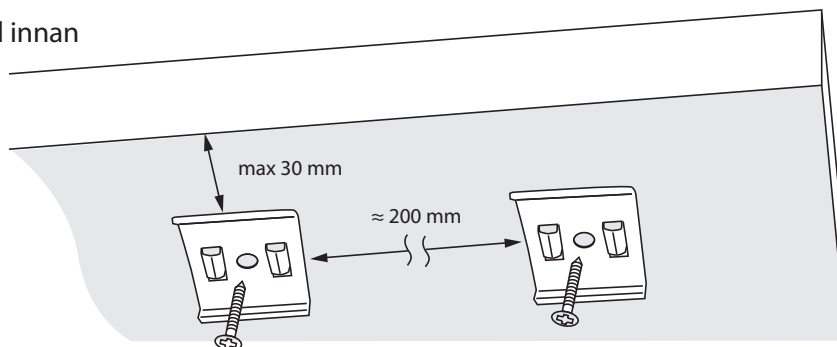

Fäst belysningens monteringskivor på max 3 cm:s avstånd från dörrens baksida och ca 20 cm från varandra. För att förenkla arbetet kan du på förhand märka ut hålen t.ex. med en märkpena.



2

Tryck fast belysningen i metallfästena.

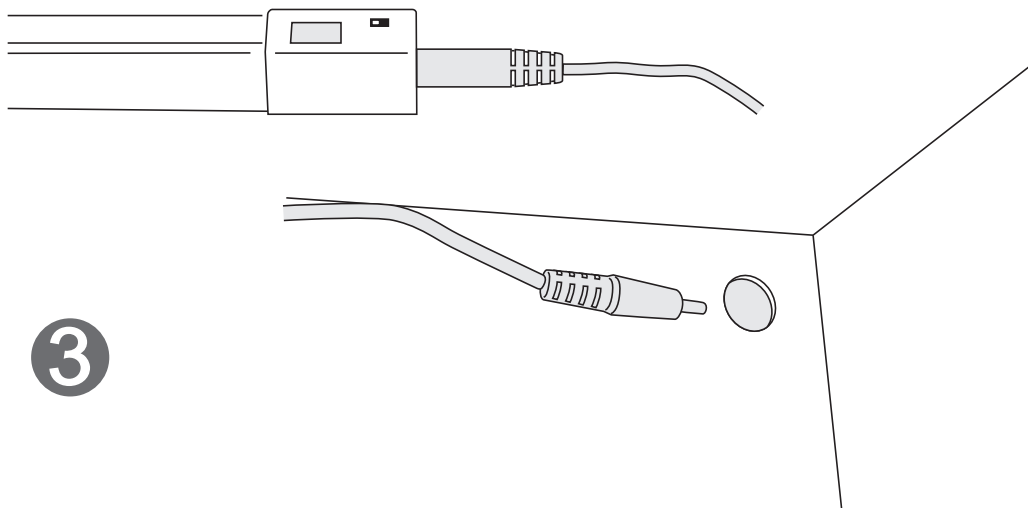

3



Sätt stickproppen i uttaget.

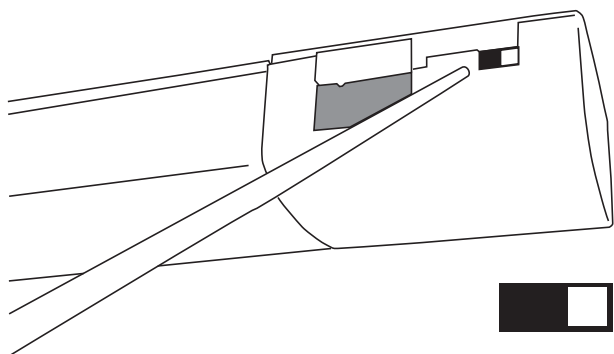

Belysningen kan användas på två sätt.

1. Skjut den lilla vita strömbrytarknappen åt höger enligt figuren, t.ex. med en tandpetare. Belysningen kan nu användas med en handrörelse. Belysningen känner av en rörelse på ca 3 cm:s avstånd.

ELLER

2. Skjut strömbrytarknappen åt vänster enligt figuren. Belysningen tänds och släcks automatiskt då dörren öppnas eller stängs.

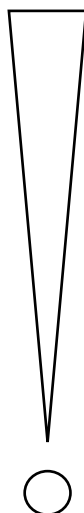
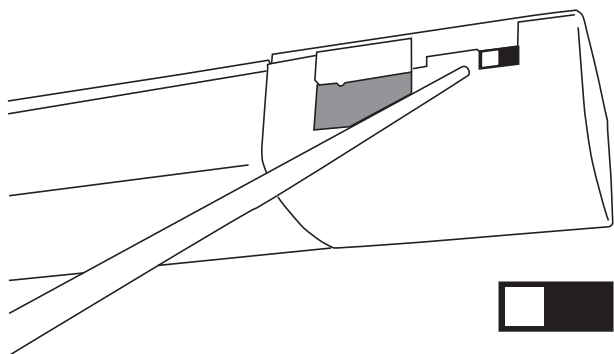

6

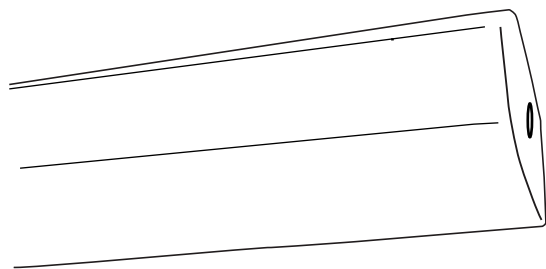

Om man vill använda belysning och transformator med strömbrytare koppla in sladden från transformatorn till andra sidan av belysningen.

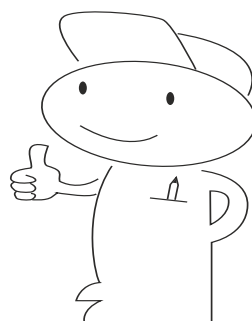

Hiipakka

- Since 1951 -

Made in Finland

Huonekalumme valmistetaan Pohjanmaalla, Kurikan Jurvassa. Nykyaikaisessa, pitkälle koneellistetussa tuotannossa työskentelee 30 kalustealan ammattilaista. Periaatteemme on toimia luotettavasti ja kannattavasti. Kehittyminen ja muutos koetaan positiivisesti ja on jatkuvuuden perusehto.

Hiipakka-kalusteiden pääraaka-aine on E1-luokan MFC-kalustelevy (Melamine Faced Chipboard), joka on tarkoitettu käytettäväksi kuivissa sisätiloissa ja on VTT:n hyväksymää. Melamiinipinnoite voidaan pyyhkiä nihkeällä ja on erittäin valonkestävä, joten kaluste pitää hyvin värinsä.

Huonekalumme toimitetaan laatikoihin pakattuna, jotta kuormittaisimme mahdollisimman vähän logistiikkaa. Pakatessa tuoteosat tarkastetaan. Porauksiin jää jonkin verran puupurua ja suosittelemme kalusteen kokoamista pakkauspuhvin päällä tai muuten suojatulla alustalla, jotta puru ja muu puupöly on helppo kerätä pois. Kotisi turvallisuuden vuoksi yli 50 cm korkea huonekalu tulee kiinnittää seinään mukana tulevilla nauhalla, joka estää kaatumisen. Koska kotien seinämateriaalit vaihtelevat, jää seinäkiinnitysruuvi/naula asiakkaan hankittavaksi.

Mikäli sinulla on kysyttävää tuotteesta, voit olla yhteydessä suoraan meihin. Kehitämme tuotteitamme jatkuvasti ja olemme kiitollisia kaikesta asiakaspalautteesta. Palaute tulee perille nopeasti kotisivujemme kautta www.hiipakka.net

Den huvudsakliga råvaran i Hiipakkas möbler är MFC-möbelskivor (Melamine Faced Chipboard) av klass E1. Dessa är avsedda att användas i torra utrymmen inomhus och har godkänts av Finlands statliga forskningscentral VTT. Melaminytan kan torkas av med en fuktig trasa och tack vare sin höga ljusbeständighet behåller möbeln färgen väl.

Vi levererar våra möbler omonterade, nedpackade i lådor för att minska transportererna. Produktdelarna kontrolleras i samband med nedpackningen. Det finns alltid kvar lite sågspån i borrhålen och därför rekommenderar vi att du monterar möbeln på förpackningskartongen eller på ett annat skyddat underlag. Då blir det enkelt att städa bort spån och annat trädamm.

Kontakta oss om du har några frågor om en produkt. Vi utvecklar hela tiden våra produkter och är tacksamma för all feedback från våra kunder. Dina kommentarer når oss snabbt via www.hiipakka.net.

**Jos sinulla on ongelmia tai kysyttävää tuotteesta, älä epäröi kysyä meiltä!
Om du har problem eller frågor om produkten, tveka inte att fråga oss!
If you have problems or questions regarding the product, do not hesitate to ask us!**

www.hiipakka.net

Puh / Tel / Phone:
+358 20 7689 500

tuotanto@ejh.fi